



# Impact Study of Limited Operation for Generator Interconnection

**GEN-2014-033**

**GEN-2014-034**

**GEN-2014-035**

**June 2015**  
**Generator Interconnection**



---

## Revision History

---

Date	Author	Change Description
6/25/2015	SPP	Impact Study of Limited Operation for Generator Interconnection GEN-2014-033 GEN-2014-034 GEN-2014-035 Report Issued

---

## Executive Summary

---

<OMITTED TEXT> (Customer) has requested a Limited Operation System Impact Study under the Southwest Power Pool Open Access Transmission Tariff (OATT) for 170 MW of solar generation to be interconnected with Energy Resource Interconnection Service (ERIS) into the Transmission System of Southwest Public Service (SPS) in Chaves County, Texas. GEN-2014-033, GEN-2014-034, GEN-2014-035 under GIA Section 5.9, has requested this Limited Operation Interconnection Study (LOIS) to determine the impacts of interconnecting to the transmission system before all required Network Upgrades identified in the DISIS-2014-002 (or most recent iteration) Impact Study can be placed into service.

This LOIS addresses the effects of interconnecting the generators to the rest of the transmission system for the system topology and conditions as expected on November 1, 2016. GEN-2014-033, GEN-2014-034, and GEN-2014-035 is requesting the interconnection three hundred forty (340) SMA 0.5 MW SC 500HE/CP 0.5MVA solar inverters and associated facilities interconnecting at the Chaves 115kV substation in Chaves County, Texas. For this LOIS, power flow analysis was conducted. The LOIS assumes that only the higher queued projects listed within Table 1 of this study might go into service before the completion of all Network Upgrades identified within Table 2 of this report. If additional generation projects, listed within Table 3, with queue priority equal to or higher than the study project request rights to go into commercial operation before all Network Upgrades identified within Table 2 of this report are completed, this LOIS may need to be restudied to ensure that interconnection service remains for the customer's request.

Power flow analysis from this LOIS has determined that the GEN-2014-033, GEN-2014-034, and GEN-2014-035 request can interconnect 118 MW of generation with Energy Resource prior to the completion of the required Network Upgrades, listed within Table 2 of this report. Should any other projects, other than those listed within Table 1 of this report, come into service an additional study may be required to determine if any limited operation service is available. It should be noted that although this LOIS analyzed many of the most probable contingencies, it is not an all-inclusive list that can account for every operational situation. Additionally, the generator may not be able to inject any power onto the Transmission System due to constraints that fall below the threshold of mitigation for a Generator Interconnection request. Because of this, it is likely that the Customers may be required to reduce their generation output to **0 MW** under certain system conditions to allow system operators to maintain the reliability of the transmission network.

Transient stability analysis was not performed for this LOIS study. The results from DISIS 2014-002 or latest iteration remain valid.

Nothing in this study should be construed as a guarantee of delivery or transmission service. If the customer wishes to sell power from the facility, a separate request for transmission service must be requested on Southwest Power Pool's OASIS by the Customer.

---

## Table of Contents

---

<b>Revision History</b> .....	<b>i</b>
<b>Executive Summary</b> .....	<b>i</b>
<b>Table of Contents</b> .....	<b>ii</b>
<b>Purpose</b> .....	<b>1</b>
<b>Facilities</b> .....	<b>5</b>
Generating Facility .....	5
Interconnection Facilities .....	5
Base Case Network Upgrades .....	5
<b>Power Flow Analysis</b> .....	<b>7</b>
Model Preparation .....	7
Study Methodology and Criteria .....	7
Results .....	7
Curtailment and System Reliability .....	8
<b>Stability Analysis</b> .....	<b>18</b>
<b>Conclusion</b> .....	<b>19</b>

---

## Purpose

---

<OMITTED TEXT> (Interconnection Customer) has requested a Limited Operation System Impact Study (LOIS) under the Southwest Power Pool (SPP) Open Access Transmission Tariff (OATT) for interconnection requests into the Transmission System of Southwest Public Service (SPS).

The purpose of this study is to reevaluate the impacts of interconnecting GEN-2014-033, GEN-2014-034, and GEN-2014-035 requests are a total of 170 MW comprised of three hundred forty (340) SMA 0.5 MW SC 500HE/CP 0.5MVA solar inverters and associated facilities interconnecting at the Chaves 115kV substation in Chaves County, Texas. The Customer has requested this amount to be studied with Energy Resource Interconnection Service (ERIS) and Network Resource Interconnection Service (NRIS) to commence on or around November 2016.

Only power flow analysis was conducted for this Limited Operation Interconnection Service. Limited Operation Studies are conducted under GIA Section 5.9.

The LOIS considers the Base Case as well as all Generating Facilities (and with respect to (b) below, any identified Network Upgrades associated with such higher queued interconnection) that, on the date the LOIS is commenced:

- a) are directly interconnected to the Transmission System;
- b) are interconnected to Affected Systems and may have an impact on the Interconnection Request;
- c) have a pending higher queued Interconnection Request to interconnect to the Transmission System listed in Table 1; or
- d) have no Queue Position but have executed an LGIA or requested that an unexecuted LGIA be filed with FERC.

Any changes to these assumptions, for example, one or more of the previously queued requests not included within this study execute an interconnection agreement and commencing commercial operation, may require a re-study of this LOIS at the expense of the Customer.

Nothing within this System Impact Study constitutes a request for transmission service or confers upon the Interconnection Customer any right to receive transmission service rights. Should the Customer require transmission service, those rights should be requested through SPP's Open Access Same-Time Information System (OASIS).

This LOIS study included prior queued generation interconnection requests. Those listed within Table 1 are the generation interconnection requests that are assumed to have rights to either full or partial interconnection service prior to the requested November 2016 in-service for this LOIS. Also listed in Table 1 are both the amount of MWs of interconnection service expected at the effective time of this study and the total MWs requested of interconnection service, the fuel type, the point of interconnection (POI), and the current status of each particular prior queued request.

Table 1: Generation Requests Included within LOIS

Project	MW	Total MW	Fuel Source	POI	Status
ASGI-2010-010	42.2	42.2		Lovington 115kV	
ASGI-2010-020	30	30		Tap LE Tatu – LE Crossroads 69kV	
ASGI-2010-021	15	15		Tap LE-Saunders Tap – LE Anderson 69kV	
ASGI-2011-001	27.3	27.3		Lovington 115kV	
ASGI-2011-003	10	10		Hendricks 115kV	
ASGI-2011-004	20	20		Pleasant Hill 69kV	
ASGI-2012-002	18.15	18.15		FE-Clovis Interchange 115kV	
ASGI-2013-002	18.4	18.4		FE Tucumcari 115kV	
ASGI-2013-003	18.4	18.4		FE Clovis 115kV	
ASGI-2013-005	1.65	1.65		FE Clovis 115kV	
ASGI-2013-006	2	2		SP-Erskine 115kV	
ASGI-2014-001	2.5	2.5		SP-Erskine 115kV	
ASGI-2014-002	49.6	49.6		Tap Tucumcari – Santa Rosa 115kV	
ASGI-2014-005	10	10		Strata 69kV	
ASGI-2014-008	10	10		South Loving 69kV	
ASGI-2014-009	10	10		Wood Draw 115kV	
ASGI-2014-010	10	10		Ochoa 115kV	
ASGI-2014-012	10	10		Cooper Ranch 115kV	
GEN-2001-033	180	180	Wind	San Juan Tap 230kV	IA FULLY EXECUTED/COMMERCIAL OPERATION
GEN-2001-036	80	80	Wind	Norton 115kV	IA FULLY EXECUTED/COMMERCIAL OPERATION
GEN-2006-018	170	170	CT	TUCO Interchange 230kV	IA FULLY EXECUTED/COMMERCIAL OPERATION
GEN-2006-026	502	502	Gas	Hobbs 230kV & Hobbs 115kV	IA FULLY EXECUTED/COMMERCIAL OPERATION
GEN-2008-022	300	300	Wind	Tap Tolk - Eddy County (Crossroads) 345kV	IA FULLY EXECUTED/ON SCHEDULE
GEN-2010-006	205	205	Gas	Jones 230kV	IA FULLY EXECUTED/COMMERCIAL OPERATION
GEN-2011-025	80	80	Wind	Tap Floyd County - Crosby County 115kV	IA FULLY EXECUTED/ON SCHEDULE
GEN-2011-046	27	27	Diesel CT	Lopez 115kV	IA FULLY EXECUTED/COMMERCIAL OPERATION
GEN-2011-048	175	175	CT	Mustang 230kV	IA FULLY EXECUTED/COMMERCIAL OPERATION
GEN-2012-001	61.2	61.2	Wind	Cirrus Tap 230kV	IA FULLY EXECUTED/COMMERCIAL OPERATION
GEN-2012-009	15	15	CT	Mustang 230kV	IA FULLY EXECUTED/ON SCHEDULE
GEN-2012-010	15	15	CT	Mustang 230kV	IA FULLY EXECUTED/ON SCHEDULE
GEN-2012-020	478	478	Wind	TUCO 230kV	IA FULLY EXECUTED/ON SCHEDULE
GEN-2012-034	7	7	CT	Mustang 230kV	IA FULLY EXECUTED/ON SCHEDULE
GEN-2012-036	7	7	CT	Mustang 230kV	IA FULLY EXECUTED/COMMERCIAL OPERATION

Table 1: Generation Requests Included within LOIS

Project	MW	Total MW	Fuel Source	POI	Status
GEN-2012-037	203	203	CT	TUCO 345kV	IA FULLY EXECUTED/ON SCHEDULE
GEN-2013-016	203	203	CT	TUCO 345kV	GIA Pending
GEN-2013-022	25	25	Solar	Norton 115kV	IA Fully Executed/On Schedule
GEN-2013-027	150	150	Wind	Tap Tolk-Yoakum 230kV	Interconnection Facility Study in progress
GEN-2014-047	40	40	Solar	Tap Tolk - Eddy County (Crossroads) 345kV	Interconnection Facility Study in progress
GEN-2014-053	80	80	Wind	Carlisle 230kV	Interconnection Facility Study in progress
GEN-2014-054	120	120	Wind	Carlisle 230kV	Interconnection Facility Study in progress
GEN-2014-066	30	30	Solar	Norton 115kV	Interconnection Facility Study in progress
GEN-2014-033	70	70	Solar	Chaves County 115kV	Interconnection Facility Study in progress
GEN-2014-034	70	70	Solar	Chaves County 115kV	Interconnection Facility Study in progress
GEN-2014-035	30	30	Solar	Chaves County 115kV	Interconnection Facility Study in progress

An additional scenario was studied without GEN 2014-053 and GEN-2014-054 in service.

This LOIS was required because the Customers are requesting interconnection prior to the completion of all of their required upgrades listed within the latest iteration of their Definitive Interconnection System Impact Study (DISIS). Table 2 below lists the required upgrade projects for which these requests have cost responsibility. GEN-2014-033, GEN-2014-034, and GEN-2014-035 were included within the DISIS-2014-002 that was studied in fall 2014 and posted January 31, 2015. The cluster has been restudied since the original posting. These reports can be located at the following Generation Interconnection Study URL:

[http://sppoasis.spp.org/documents/swpp/transmission/GenStudies.cfm?YearType=2014\\_Impact\\_Studies](http://sppoasis.spp.org/documents/swpp/transmission/GenStudies.cfm?YearType=2014_Impact_Studies)

Table 2: Upgrade Projects not included but Required for Full Interconnection Service

Upgrade Project	Type	Description	Status
Deaf Smith – Plant X 230kV circuit #1	Terminal Equipment	Replace Wave trap at Deaf Smith	
Oklaunion 345kV Reactive Power Support	SVC and Capacitor Bank	Install 150Mvar Capacitor Bank(s) and 150Mvar SVC at Oklaunion	
Tolk – Plant X 230kV circuit #3	New Line	Build a 3 <sup>rd</sup> 230kV circuit between Tolk and Plant X	

*Table 2: Upgrade Projects not included but Required for Full Interconnection Service*

Upgrade Project	Type	Description	Status
Tuco 2 Substation Upgrade 345kV/230kV	New Substation	Tap Border – Tuco 345kV and build new 345kV substation and 345/230kV transformer and tie on TUCO – Swisher 230kV	

Any changes to these assumptions, for example, one or more of the previously queued requests not included within this study execute an interconnection agreement and commencing commercial operation, may require a re-study of this LOIS at the expense of the Customer.

The higher or equally queued projects that were not included in this study are listed in Table 3. While this list is not all inclusive it is a list of the most probable and affecting prior queued requests that were not included within this LOIS, either because no request for an LOIS has been made or the request is on suspension, etc.

*Table 3: Higher or Equally Queued GI Requests not included within LOIS*

Project	MW	Total MW	Fuel Source	POI	Status
GEN-2010-046	56.0	56.0	Gas	TUCO Interchange 230kV	IA FULLY EXECUTED/ON SCHEDULE
GEN-2014-012	225.0	225.0	Gas	Tap Hobbs Interchange - Andrews 230kV	GIA Pending

Additionally, the customer requested a scenario with the following generation changes listed in Table 4. This scenario was also studied with and without GEN 2014-053 and GEN-2014-054 in service.

*Table 4: Higher or Equally Queued GI Requests not included within LOIS*

Project	MW	Total MW	Fuel Source	POI	Status
GEN-2001-033	120	180	Wind	San Juan Tap 230kV	IA FULLY EXECUTED/COMMERCIAL OPERATION
GEN-2013-027	In-service 6/1/2018	150	Wind	Tap Tolk-Yoakum 230kV	Interconnection Facility Study in progress

Nothing in this System Impact Study constitutes a request for transmission service or grants the Interconnection Customer any rights to transmission service.



# Facilities

## Generating Facility

The Interconnection Customer’s request to interconnect a total of 170 MW is comprised of three hundred forty (340) SMA 0.5 MW SC 500HE/CP 0.5MVA solar inverters and associated facilities.

## Interconnection Facilities

The POI for GEN-2014-033, GEN-2014-034, and GEN-2014-035 Interconnection Customer is the Chaves 115kV substation in Chaves County, Texas. Figure 1 depicts the one-line diagram of the local transmission system including the POI as well as the power flow model representing the requests.

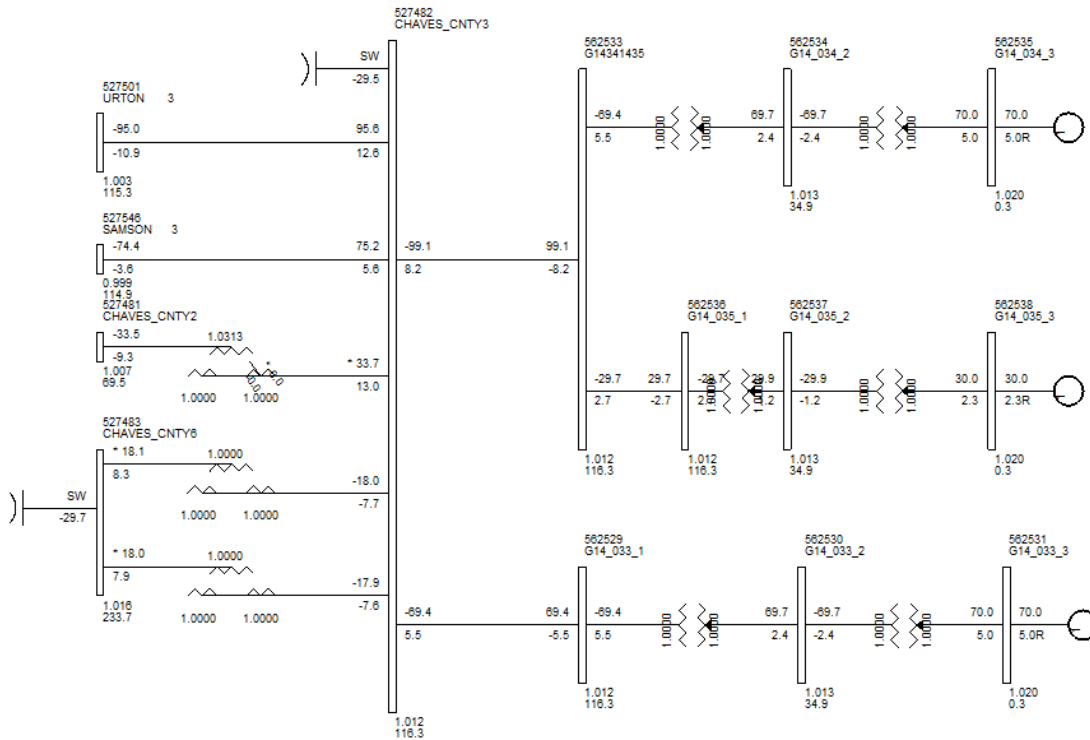

Figure 1: Proposed POI Configuration and Request Power Flow Model

## Base Case Network Upgrades

The Network Upgrades included within the cases used for this LOIS study are those facilities that are a part of the SPP Transmission Expansion Plan or the Balanced Portfolio projects that have in-service dates prior to the GEN-2014-033, GEN-2014-034, and GEN-2014-035 LOIS requested in-service date of November 1, 2015. These facilities have an approved Notification to Construct (NTC), or are in construction stages and expected to be in-service at the effective time of this study. No other upgrades were included for this LOIS. If for some reason, construction on these projects is

delayed or discontinued, a restudy may be needed to determine the interconnection service availability of the Customer.

---

# Power Flow Analysis

---

Power flow analysis is used to determine if the transmission system can accommodate the injection from the request without violating thermal or voltage transmission planning criteria.

## Model Preparation

Power flow analysis was performed using modified versions of the 2014 series of transmission service request study models including the 2015 (spring and summer) seasonal models. To incorporate the Interconnection Customer's request, a re-dispatch of existing generation within SPP was performed with respect to the amount of the Customer's injection and the interconnecting Balancing Authority. This method allows the request to be studied as a Network Resource (NRIS) Interconnection Request. For this LOIS, only the previous queued requests listed in Table 1 were assumed to be in-service.

## Study Methodology and Criteria

The ACCC function of PSS/E is used to simulate contingencies, including single and multiple facility (i.e. breaker-to-breaker, etc.) outages, within all of the control areas of SPP and other control areas external to SPP and the resulting data analyzed. This satisfies the "more probable" contingency testing criteria mandated by NERC and the SPP criteria.

The contingency set includes all SPP control area branches and ties 69kV and above, first tier Non-SPP control area branches and ties 115 kV and above, any defined contingencies for these control areas, and generation unit outages for the SPP control areas with SPP reserve share program redispatch.

The monitor elements include all SPP control area branches, ties, and buses 69 kV and above, and all first tier Non-SPP control area branches and ties 69 kV and above. NERC Power Transfer Distribution Flowgates for SPP and first tier Non-SPP control area are monitored. Additional NERC Flowgates are monitored in second tier or greater Non-SPP control areas. Voltage monitoring was performed for SPP control area buses 69 kV and above.

## Results

The LOIS ACCC analysis indicates that the Customers can interconnect their generation into the SPS transmission system at a reduced rate before all required upgrades listed within the DISIS-2014-002 study or latest iteration can be placed into service. Should any other GI projects, other than those listed within Table 1 of this report, come into service an additional study may be required to determine if any limited operation service is available.

ACCC results for the LOIS can be found in Table 5, 6, 7, 8, and 9 below. Table 9 has the overloads that are less than 20% TDF and are not for mitigation. Generator Interconnection Energy Resource analysis doesn't mitigate for those issues in which the affecting GI request has less than a 20% OTDF, Table 9 is provided for informational purposes only so that the Customer understands there may be operational conditions when they may be required to reduce their output to maintain system reliability.

## **Curtailment and System Reliability**

In no way does this study guarantee operation for all periods of time. It should be noted that although this study analyzed many of the most probable contingencies, it is not an all-inclusive list and cannot account for every operational situation. Because of this, it is likely that the Customer may be required to reduce their generation output to **0 MW** under certain system conditions to allow system operators to maintain the reliability of the transmission network.

Power Flow Analysis

Table5: Interconnection Constraints for Mitigation of LOIS @ 170MW

Season	Dispatch Group	Source	Flow	Monitored Element	RATEA (MVA)	RATEB (MVA)	TDF	TC% LOADING	Max MW Available	Contingency
15G	06ALL	G14_033	'TO->FROM'	'PLANT X STATION - TOLK STATION WEST 230KV CKT 1'	478	502	0.36562	103.6897	67.5	'PLANT X STATION - TOLK STATION EAST 230KV CKT 2'
15G	06ALL	G14_034	'TO->FROM'	'PLANT X STATION - TOLK STATION WEST 230KV CKT 1'	478	502	0.36562	103.6897	67.5	'PLANT X STATION - TOLK STATION EAST 230KV CKT 2'
15G	06ALL	G14_035	'TO->FROM'	'PLANT X STATION - TOLK STATION WEST 230KV CKT 1'	478	502	0.36562	103.6897	28.9	'PLANT X STATION - TOLK STATION EAST 230KV CKT 2'
15G	06ALL	G14_033	'TO->FROM'	'PLANT X STATION - TOLK STATION EAST 230KV CKT 2'	478	502	0.36238	102.897	68	'PLANT X STATION - TOLK STATION WEST 230KV CKT 1'
15G	06ALL	G14_034	'TO->FROM'	'PLANT X STATION - TOLK STATION EAST 230KV CKT 2'	478	502	0.36238	102.897	68	'PLANT X STATION - TOLK STATION WEST 230KV CKT 1'
15G	06ALL	G14_035	'TO->FROM'	'PLANT X STATION - TOLK STATION EAST 230KV CKT 2'	478	502	0.36238	102.897	29.1	'PLANT X STATION - TOLK STATION WEST 230KV CKT 1'
15SP	06ALL	G14_033	'TO->FROM'	'PLANT X STATION - TOLK STATION WEST 230KV CKT 1'	478	502	0.36671	131.7326	48.69	'PLANT X STATION - TOLK STATION EAST 230KV CKT 2'
15SP	06ALL	G14_034	'TO->FROM'	'PLANT X STATION - TOLK STATION WEST 230KV CKT 1'	478	502	0.36671	131.7326	48.69	'PLANT X STATION - TOLK STATION EAST 230KV CKT 2'
15SP	06ALL	G14_035	'TO->FROM'	'PLANT X STATION - TOLK STATION WEST 230KV CKT 1'	478	502	0.36671	131.7326	20.86	'PLANT X STATION - TOLK STATION EAST 230KV CKT 2'
15SP	06ALL	G14_033	'TO->FROM'	'PLANT X STATION - TOLK STATION EAST 230KV CKT 2'	478	502	0.36348	130.732	49.3	'PLANT X STATION - TOLK STATION WEST 230KV CKT 1'
15SP	06ALL	G14_034	'TO->FROM'	'PLANT X STATION - TOLK STATION EAST 230KV CKT 2'	478	502	0.36348	130.732	49.3	'PLANT X STATION - TOLK STATION WEST 230KV CKT 1'
15SP	06ALL	G14_035	'TO->FROM'	'PLANT X STATION - TOLK STATION EAST 230KV CKT 2'	478	502	0.36348	130.732	21.1	'PLANT X STATION - TOLK STATION WEST 230KV CKT 1'
15G	06ALL	G14_033	'FROM->TO'	'TUCO INTERCHANGE (SIEM 8743066) 345/230/13.2KV TRANSFORMER CKT 2'	560	644	0.41009	111.7899	63.2	'TUCO INTERCHANGE (GE M1022338) 345/230/13.2KV TRANSFORMER CKT 1'
15G	06ALL	G14_034	'FROM->TO'	'TUCO INTERCHANGE (SIEM 8743066) 345/230/13.2KV TRANSFORMER CKT 2'	560	644	0.41009	111.7899	63.2	'TUCO INTERCHANGE (GE M1022338) 345/230/13.2KV TRANSFORMER CKT 1'
15G	06ALL	G14_035	'FROM->TO'	'TUCO INTERCHANGE (SIEM 8743066) 345/230/13.2KV TRANSFORMER CKT 2'	560	644	0.41009	111.7899	27	'TUCO INTERCHANGE (GE M1022338) 345/230/13.2KV TRANSFORMER CKT 1'
15G	06ALL	G14_053	'FROM->TO'	'TUCO INTERCHANGE (SIEM 8743066) 345/230/13.2KV TRANSFORMER CKT 2'	560	644	0.49332	111.7899	70.6	'TUCO INTERCHANGE (GE M1022338) 345/230/13.2KV TRANSFORMER CKT 1'
15G	06ALL	G14_054	'FROM->TO'	'TUCO INTERCHANGE (SIEM 8743066) 345/230/13.2KV TRANSFORMER CKT 2'	560	644	0.49332	111.7899	106	'TUCO INTERCHANGE (GE M1022338) 345/230/13.2KV TRANSFORMER CKT 1'
15G	06ALL	G14_033	'FROM->TO'	'TUCO INTERCHANGE (GE M1022338) 345/230/13.2KV TRANSFORMER CKT 1'	560	560	0.4154	130.1147	54.9	'TUCO INTERCHANGE (SIEM 8743066) 345/230/13.2KV TRANSFORMER CKT 2'
15G	06ALL	G14_034	'FROM->TO'	'TUCO INTERCHANGE (GE M1022338) 345/230/13.2KV TRANSFORMER CKT 1'	560	560	0.4154	130.1147	54.9	'TUCO INTERCHANGE (SIEM 8743066) 345/230/13.2KV TRANSFORMER CKT 2'
15G	06ALL	G14_035	'FROM->TO'	'TUCO INTERCHANGE (GE M1022338) 345/230/13.2KV TRANSFORMER CKT 1'	560	560	0.4154	130.1147	23.5	'TUCO INTERCHANGE (SIEM 8743066) 345/230/13.2KV TRANSFORMER CKT 2'
15G	06ALL	G14_053	'FROM->TO'	'TUCO INTERCHANGE (GE M1022338) 345/230/13.2KV TRANSFORMER CKT 1'	560	560	0.49971	130.1147	59.3	'TUCO INTERCHANGE (SIEM 8743066) 345/230/13.2KV TRANSFORMER CKT 2'

Power Flow Analysis

Season	Dispatch Group	Source	Flow	Monitored Element	RATEA (MVA)	RATEB (MVA)	TDF	TC% LOADING	Max MW Available	Contingency
15G	06ALL	G14_054	'FROM->TO'	'TUCO INTERCHANGE (GE M1022338) 345/230/13.2KV TRANSFORMER CKT 1'	560	560	0.49971	130.1147	88.9	'TUCO INTERCHANGE (SIEM 8743066) 345/230/13.2KV TRANSFORMER CKT 2'

Table 6: Constraints of LOIS @ 140MW without GEN 2014-035, GEN 2014-053, and GEN 2014-054

Season	Dispatch Group	Source	Flow	Monitored Element	RATEA (MVA)	RATEB (MVA)	TDF	TC% LOADING	Max Available	Contingency
15SP	06ALL	G14_033	'TO->FROM'	'PLANT X STATION - TOLK STATION WEST 230KV CKT 1'	478	502	0.36664	126.2813	51.2	'PLANT X STATION - TOLK STATION EAST 230KV CKT 2'
15SP	06ALL	G14_034	'TO->FROM'	'PLANT X STATION - TOLK STATION WEST 230KV CKT 1'	478	502	0.36664	126.2813	51.2	'PLANT X STATION - TOLK STATION EAST 230KV CKT 2'
15SP	06ALL	G14_033	'TO->FROM'	'PLANT X STATION - TOLK STATION EAST 230KV CKT 2'	478	502	0.36342	125.317	51.9	'PLANT X STATION - TOLK STATION WEST 230KV CKT 1'
15SP	06ALL	G14_034	'TO->FROM'	'PLANT X STATION - TOLK STATION EAST 230KV CKT 2'	478	502	0.36342	125.317	51.9	'PLANT X STATION - TOLK STATION WEST 230KV CKT 1'
15G	06ALL	G14_033	'FROM->TO'	'TUCO INTERCHANGE (GE M1022338) 345/230/13.2KV TRANSFORMER CKT 1'	560	560	0.41667	105.777	64.7	'TUCO INTERCHANGE (SIEM 8743066) 345/230/13.2KV TRANSFORMER CKT 2'
15G	06ALL	G14_034	'FROM->TO'	'TUCO INTERCHANGE (GE M1022338) 345/230/13.2KV TRANSFORMER CKT 1'	560	560	0.41667	105.777	64.7	'TUCO INTERCHANGE (SIEM 8743066) 345/230/13.2KV TRANSFORMER CKT 2'

Table 7: Constraints of LOIS @170MW for customer requested scenario with GEN-2014-053 and GEN-2014-054

Season	Dispatch Group	Source	Flow	Monitored Element	RATEA (MVA)	RATEB (MVA)	TDF	TC% LOADING	Max Available	Contingency
15SP	06ALL	G14_033	'TO->FROM'	'PLANT X STATION - TOLK STATION WEST 230KV CKT 1'	478	502	0.36662	112.6683	61.4	'PLANT X STATION - TOLK STATION EAST 230KV CKT 2'
15SP	06ALL	G14_034	'TO->FROM'	'PLANT X STATION - TOLK STATION WEST 230KV CKT 1'	478	502	0.36662	112.6683	61.4	'PLANT X STATION - TOLK STATION EAST 230KV CKT 2'
15SP	06ALL	G14_035	'TO->FROM'	'PLANT X STATION - TOLK STATION WEST 230KV CKT 1'	478	502	0.36662	112.6683	26.35	'PLANT X STATION - TOLK STATION EAST 230KV CKT 2'
15SP	06ALL	G14_033	'TO->FROM'	'PLANT X STATION - TOLK STATION EAST 230KV CKT 2'	478	502	0.36339	111.8062	61.5	'PLANT X STATION - TOLK STATION WEST 230KV CKT 1'
15SP	06ALL	G14_034	'TO->FROM'	'PLANT X STATION - TOLK STATION EAST 230KV CKT 2'	478	502	0.36339	111.8062	61.5	'PLANT X STATION - TOLK STATION WEST 230KV CKT 1'
15SP	06ALL	G14_035	'TO->FROM'	'PLANT X STATION - TOLK STATION EAST 230KV CKT 2'	478	502	0.36339	111.8062	26.3	'PLANT X STATION - TOLK STATION WEST 230KV CKT 1'
15G	06ALL	G14_033	'FROM->TO'	'TUCO INTERCHANGE (GE M1022338) 345/230/13.2KV TRANSFORMER CKT 1'	560	560	0.41691	110.9506	60.3	'TUCO INTERCHANGE (SIEM 8743066) 345/230/13.2KV TRANSFORMER CKT 2'
15G	06ALL	G14_034	'FROM->TO'	'TUCO INTERCHANGE (GE M1022338) 345/230/13.2KV TRANSFORMER CKT 1'	560	560	0.41691	110.9506	60.3	'TUCO INTERCHANGE (SIEM 8743066) 345/230/13.2KV TRANSFORMER CKT 2'

Power Flow Analysis

Season	Dispatch Group	Source	Flow	Monitored Element	RATEA (MVA)	RATEB (MVA)	TDF	TC% LOADING	Max Available	Contingency
15G	06ALL	G14_035	'FROM->TO'	'TUCO INTERCHANGE (GE M1022338) 345/230/13.2KV TRANSFORMER CKT 1'	560	560	0.41691	110.9506	25.8	'TUCO INTERCHANGE (SIEM 8743066) 345/230/13.2KV TRANSFORMER CKT 2'
15G	06ALL	G14_053	'FROM->TO'	'TUCO INTERCHANGE (GE M1022338) 345/230/13.2KV TRANSFORMER CKT 1'	560	560	0.50121	110.9506	66.7	'TUCO INTERCHANGE (SIEM 8743066) 345/230/13.2KV TRANSFORMER CKT 2'
15G	06ALL	G14_054	'FROM->TO'	'TUCO INTERCHANGE (GE M1022338) 345/230/13.2KV TRANSFORMER CKT 1'	560	560	0.50121	110.9506	100	'TUCO INTERCHANGE (SIEM 8743066) 345/230/13.2KV TRANSFORMER CKT 2'

Table 8: Constraints of LOIS @170MW for customer requested scenario without GEN-2014-053 and GEN-2014-054

Season	Dispatch Group	Source	Flow	Monitored Element	RATEA (MVA)	RATEB (MVA)	TDF	TC% LOADING	Max Available	Contingency
15SP	06ALL	G14_033	'TO->FROM'	'PLANT X STATION - TOLK STATION WEST 230KV CKT 1'	478	502	0.3666	109.4219	63.6	'PLANT X STATION - TOLK STATION EAST 230KV CKT 2'
15SP	06ALL	G14_034	'TO->FROM'	'PLANT X STATION - TOLK STATION WEST 230KV CKT 1'	478	502	0.3666	109.4219	63.6	'PLANT X STATION - TOLK STATION EAST 230KV CKT 2'
15SP	06ALL	G14_035	'TO->FROM'	'PLANT X STATION - TOLK STATION WEST 230KV CKT 1'	478	502	0.3666	109.4219	27.2	'PLANT X STATION - TOLK STATION EAST 230KV CKT 2'
15SP	06ALL	G14_033	'TO->FROM'	'PLANT X STATION - TOLK STATION EAST 230KV CKT 2'	478	502	0.36337	108.5837	64.2	'PLANT X STATION - TOLK STATION WEST 230KV CKT 1'
15SP	06ALL	G14_034	'TO->FROM'	'PLANT X STATION - TOLK STATION EAST 230KV CKT 2'	478	502	0.36337	108.5837	64.2	'PLANT X STATION - TOLK STATION WEST 230KV CKT 1'
15SP	06ALL	G14_035	'TO->FROM'	'PLANT X STATION - TOLK STATION EAST 230KV CKT 2'	478	502	0.36337	108.5837	27.5	'PLANT X STATION - TOLK STATION WEST 230KV CKT 1'

Table 9: Constraints not for mitigation @ 170MW

Season	Dispatch Group	Source	Flow	Monitored Element	RATEA (MVA)	RATEB (MVA)	TDF	TC% LOADING	Contingency
15G	06ALL	G14_033	'TO->FROM'	'FPL SWITCH - WOODWARD 138KV CKT 1'	133	153	0.04669	124.1693	'OKLAUNION - TUCO INTERCHANGE 345KV CKT 1'
15G	06ALL	G14_035	'TO->FROM'	'FPL SWITCH - WOODWARD 138KV CKT 1'	133	153	0.04669	124.1693	'OKLAUNION - TUCO INTERCHANGE 345KV CKT 1'
15G	06ALL	G14_034	'TO->FROM'	'FPL SWITCH - WOODWARD 138KV CKT 1'	133	153	0.04669	124.1693	'OKLAUNION - TUCO INTERCHANGE 345KV CKT 1'
15G	06ALL	G14_053	'TO->FROM'	'FPL SWITCH - WOODWARD 138KV CKT 1'	133	153	0.04981	124.1693	'OKLAUNION - TUCO INTERCHANGE 345KV CKT 1'
15G	06ALL	G14_054	'TO->FROM'	'FPL SWITCH - WOODWARD 138KV CKT 1'	133	153	0.04981	124.1693	'OKLAUNION - TUCO INTERCHANGE 345KV CKT 1'
15G	06ALL	G14_033	'TO->FROM'	'FPL SWITCH - WOODWARD 138KV CKT 1'	133	153	0.04195	126.8783	'ELK CITY 230KV - SWEETWATER 230KV CKT 1'
15G	06ALL	G14_035	'TO->FROM'	'FPL SWITCH - WOODWARD 138KV CKT 1'	133	153	0.04195	126.8783	'ELK CITY 230KV - SWEETWATER 230KV CKT 1'
15G	06ALL	G14_034	'TO->FROM'	'FPL SWITCH - WOODWARD 138KV CKT 1'	133	153	0.04195	126.8783	'ELK CITY 230KV - SWEETWATER 230KV CKT 1'
15G	06ALL	G14_053	'TO->FROM'	'FPL SWITCH - WOODWARD 138KV CKT 1'	133	153	0.03917	126.8783	'ELK CITY 230KV - SWEETWATER 230KV CKT 1'
15G	06ALL	G14_054	'TO->FROM'	'FPL SWITCH - WOODWARD 138KV CKT 1'	133	153	0.03917	126.8783	'ELK CITY 230KV - SWEETWATER 230KV CKT 1'
15G	06ALL	G14_033	'TO->FROM'	'FPL SWITCH - WOODWARD 138KV CKT 1'	133	153	0.04195	117.976	'STLN-DEMARC6 - SWEETWATER 230KV CKT 1'
15G	06ALL	G14_035	'TO->FROM'	'FPL SWITCH - WOODWARD 138KV CKT 1'	133	153	0.04195	117.976	'STLN-DEMARC6 - SWEETWATER 230KV CKT 1'

Power Flow Analysis

Season	Dispatch Group	Source	Flow	Monitored Element	RATEA (MVA)	RATEB (MVA)	TDF	TC% LOADING	Contingency
15G	06ALL	G14_034	'TO->FROM'	'FPL SWITCH - WOODWARD 138KV CKT 1'	133	153	0.04195	117.976	'STLN-DEMARC6 - SWEETWATER 230KV CKT 1'
15G	06ALL	G14_053	'TO->FROM'	'FPL SWITCH - WOODWARD 138KV CKT 1'	133	153	0.03917	117.976	'STLN-DEMARC6 - SWEETWATER 230KV CKT 1'
15G	06ALL	G14_054	'TO->FROM'	'FPL SWITCH - WOODWARD 138KV CKT 1'	133	153	0.03917	117.976	'STLN-DEMARC6 - SWEETWATER 230KV CKT 1'
15G	06ALL	G14_033	'TO->FROM'	'FPL SWITCH - WOODWARD 138KV CKT 1'	133	153	0.03159	104.3862	'ELLIS 4 138.00 - MOREWOOD SW 138KV CKT 1'
15G	06ALL	G14_035	'TO->FROM'	'FPL SWITCH - WOODWARD 138KV CKT 1'	133	153	0.03159	104.3862	'ELLIS 4 138.00 - MOREWOOD SW 138KV CKT 1'
15G	06ALL	G14_034	'TO->FROM'	'FPL SWITCH - WOODWARD 138KV CKT 1'	133	153	0.03159	104.3862	'ELLIS 4 138.00 - MOREWOOD SW 138KV CKT 1'
15G	06ALL	G14_053	'TO->FROM'	'FPL SWITCH - WOODWARD 138KV CKT 1'	133	153	0.03086	104.3862	'ELLIS 4 138.00 - MOREWOOD SW 138KV CKT 1'
15G	06ALL	G14_054	'TO->FROM'	'FPL SWITCH - WOODWARD 138KV CKT 1'	133	153	0.03086	104.3862	'ELLIS 4 138.00 - MOREWOOD SW 138KV CKT 1'
15G	06ALL	G14_033	'TO->FROM'	'FPL SWITCH - WOODWARD 138KV CKT 1'	133	153	0.03159	106.4937	'ELLIS 4 138.00 - RED HILLS WIND 138KV CKT 1'
15G	06ALL	G14_035	'TO->FROM'	'FPL SWITCH - WOODWARD 138KV CKT 1'	133	153	0.03159	106.4937	'ELLIS 4 138.00 - RED HILLS WIND 138KV CKT 1'
15G	06ALL	G14_034	'TO->FROM'	'FPL SWITCH - WOODWARD 138KV CKT 1'	133	153	0.03159	106.4937	'ELLIS 4 138.00 - RED HILLS WIND 138KV CKT 1'
15G	06ALL	G14_053	'TO->FROM'	'FPL SWITCH - WOODWARD 138KV CKT 1'	133	153	0.03086	106.4937	'ELLIS 4 138.00 - RED HILLS WIND 138KV CKT 1'
15G	06ALL	G14_054	'TO->FROM'	'FPL SWITCH - WOODWARD 138KV CKT 1'	133	153	0.03086	106.4937	'ELLIS 4 138.00 - RED HILLS WIND 138KV CKT 1'
15G	06ALL	G14_033	'TO->FROM'	'FPL SWITCH - WOODWARD 138KV CKT 1'	133	153	0.03183	114.0569	'WOODWARD - WOODWARD 69KV CKT 1'
15G	06ALL	G14_035	'TO->FROM'	'FPL SWITCH - WOODWARD 138KV CKT 1'	133	153	0.03183	114.0569	'WOODWARD - WOODWARD 69KV CKT 1'
15G	06ALL	G14_034	'TO->FROM'	'FPL SWITCH - WOODWARD 138KV CKT 1'	133	153	0.03183	114.0569	'WOODWARD - WOODWARD 69KV CKT 1'
15G	06ALL	G14_053	'TO->FROM'	'FPL SWITCH - WOODWARD 138KV CKT 1'	133	153	0.03165	114.0569	'WOODWARD - WOODWARD 69KV CKT 1'
15G	06ALL	G14_054	'TO->FROM'	'FPL SWITCH - WOODWARD 138KV CKT 1'	133	153	0.03165	114.0569	'WOODWARD - WOODWARD 69KV CKT 1'
15G	06ALL	G14_033	'TO->FROM'	'FPL SWITCH - WOODWARD 138KV CKT 1'	133	153	0.03386	118.408	'DEWEY - IODINE 138KV CKT 1'
15G	06ALL	G14_035	'TO->FROM'	'FPL SWITCH - WOODWARD 138KV CKT 1'	133	153	0.03386	118.408	'DEWEY - IODINE 138KV CKT 1'
15G	06ALL	G14_034	'TO->FROM'	'FPL SWITCH - WOODWARD 138KV CKT 1'	133	153	0.03386	118.408	'DEWEY - IODINE 138KV CKT 1'
15G	06ALL	G14_053	'TO->FROM'	'FPL SWITCH - WOODWARD 138KV CKT 1'	133	153	0.03349	118.408	'DEWEY - IODINE 138KV CKT 1'
15G	06ALL	G14_054	'TO->FROM'	'FPL SWITCH - WOODWARD 138KV CKT 1'	133	153	0.03349	118.408	'DEWEY - IODINE 138KV CKT 1'
15G	06ALL	G14_033	'TO->FROM'	'FPL SWITCH - WOODWARD 138KV CKT 1'	133	153	0.03386	119.9913	'IODINE - WOODWARD EHV 138KV CKT 1'
15G	06ALL	G14_035	'TO->FROM'	'FPL SWITCH - WOODWARD 138KV CKT 1'	133	153	0.03386	119.9913	'IODINE - WOODWARD EHV 138KV CKT 1'
15G	06ALL	G14_034	'TO->FROM'	'FPL SWITCH - WOODWARD 138KV CKT 1'	133	153	0.03386	119.9913	'IODINE - WOODWARD EHV 138KV CKT 1'
15G	06ALL	G14_053	'TO->FROM'	'FPL SWITCH - WOODWARD 138KV CKT 1'	133	153	0.03349	119.9913	'IODINE - WOODWARD EHV 138KV CKT 1'
15G	06ALL	G14_054	'TO->FROM'	'FPL SWITCH - WOODWARD 138KV CKT 1'	133	153	0.03349	119.9913	'IODINE - WOODWARD EHV 138KV CKT 1'
15G	06ALL	G14_033	'TO->FROM'	'FPL SWITCH - WOODWARD 138KV CKT 1'	133	153	0.04556	139.4192	'NORTHWEST - TATONGA7 345.00 345KV CKT 1'
15G	06ALL	G14_035	'TO->FROM'	'FPL SWITCH - WOODWARD 138KV CKT 1'	133	153	0.04556	139.4192	'NORTHWEST - TATONGA7 345.00 345KV CKT 1'
15G	06ALL	G14_034	'TO->FROM'	'FPL SWITCH - WOODWARD 138KV CKT 1'	133	153	0.04556	139.4192	'NORTHWEST - TATONGA7 345.00 345KV CKT 1'
15G	06ALL	G14_053	'TO->FROM'	'FPL SWITCH - WOODWARD 138KV CKT 1'	133	153	0.04446	139.4192	'NORTHWEST - TATONGA7 345.00 345KV CKT 1'
15G	06ALL	G14_054	'TO->FROM'	'FPL SWITCH - WOODWARD 138KV CKT 1'	133	153	0.04446	139.4192	'NORTHWEST - TATONGA7 345.00 345KV CKT 1'
15G	06ALL	G14_033	'TO->FROM'	'FPL SWITCH - WOODWARD 138KV CKT 1'	133	153	0.04556	126.525	'G11_051T 345.00 - WOODWARD DISTRICT EHV 345KV CKT 1'
15G	06ALL	G14_035	'TO->FROM'	'FPL SWITCH - WOODWARD 138KV CKT 1'	133	153	0.04556	126.525	'G11_051T 345.00 - WOODWARD DISTRICT EHV 345KV CKT 1'
15G	06ALL	G14_034	'TO->FROM'	'FPL SWITCH - WOODWARD 138KV CKT 1'	133	153	0.04556	126.525	'G11_051T 345.00 - WOODWARD DISTRICT EHV 345KV CKT 1'
15G	06ALL	G14_053	'TO->FROM'	'FPL SWITCH - WOODWARD 138KV CKT 1'	133	153	0.04446	126.525	'G11_051T 345.00 - WOODWARD DISTRICT EHV 345KV CKT 1'
15G	06ALL	G14_054	'TO->FROM'	'FPL SWITCH - WOODWARD 138KV CKT 1'	133	153	0.04446	126.525	'G11_051T 345.00 - WOODWARD DISTRICT EHV 345KV CKT 1'



Power Flow Analysis

Season	Dispatch Group	Source	Flow	Monitored Element	RATEA (MVA)	RATEB (MVA)	TDF	TC% LOADING	Contingency
15G	06ALL	G14_033	'TO->FROM'	'FPL SWITCH - WOODWARD 138KV CKT 1'	133	153	0.04556	126.2581	'G11_051T 345.00 - TATONGA7 345.00 345KV CKT 1'
15G	06ALL	G14_035	'TO->FROM'	'FPL SWITCH - WOODWARD 138KV CKT 1'	133	153	0.04556	126.2581	'G11_051T 345.00 - TATONGA7 345.00 345KV CKT 1'
15G	06ALL	G14_034	'TO->FROM'	'FPL SWITCH - WOODWARD 138KV CKT 1'	133	153	0.04556	126.2581	'G11_051T 345.00 - TATONGA7 345.00 345KV CKT 1'
15G	06ALL	G14_053	'TO->FROM'	'FPL SWITCH - WOODWARD 138KV CKT 1'	133	153	0.04446	126.2581	'G11_051T 345.00 - TATONGA7 345.00 345KV CKT 1'
15G	06ALL	G14_054	'TO->FROM'	'FPL SWITCH - WOODWARD 138KV CKT 1'	133	153	0.04446	126.2581	'G11_051T 345.00 - TATONGA7 345.00 345KV CKT 1'
15G	06ALL	G14_033	'TO->FROM'	'FPL SWITCH - WOODWARD 138KV CKT 1'	133	153	0.03419	108.3419	'FINNEY SWITCHING STATION - Hitchland Interchange 345KV CKT 1'
15G	06ALL	G14_035	'TO->FROM'	'FPL SWITCH - WOODWARD 138KV CKT 1'	133	153	0.03419	108.3419	'FINNEY SWITCHING STATION - Hitchland Interchange 345KV CKT 1'
15G	06ALL	G14_034	'TO->FROM'	'FPL SWITCH - WOODWARD 138KV CKT 1'	133	153	0.03419	108.3419	'FINNEY SWITCHING STATION - Hitchland Interchange 345KV CKT 1'
15G	06ALL	G14_053	'TO->FROM'	'FPL SWITCH - WOODWARD 138KV CKT 1'	133	153	0.03339	108.3419	'FINNEY SWITCHING STATION - Hitchland Interchange 345KV CKT 1'
15G	06ALL	G14_054	'TO->FROM'	'FPL SWITCH - WOODWARD 138KV CKT 1'	133	153	0.03339	108.3419	'FINNEY SWITCHING STATION - Hitchland Interchange 345KV CKT 1'
15G	06ALL	G14_033	'TO->FROM'	'FPL SWITCH - WOODWARD 138KV CKT 1'	133	153	0.04195	123.349	'GRAPEVINE INTERCHANGE - STATELINE INTERCHANGE 230KV CKT 1'
15G	06ALL	G14_035	'TO->FROM'	'FPL SWITCH - WOODWARD 138KV CKT 1'	133	153	0.04195	123.349	'GRAPEVINE INTERCHANGE - STATELINE INTERCHANGE 230KV CKT 1'
15G	06ALL	G14_034	'TO->FROM'	'FPL SWITCH - WOODWARD 138KV CKT 1'	133	153	0.04195	123.349	'GRAPEVINE INTERCHANGE - STATELINE INTERCHANGE 230KV CKT 1'
15G	06ALL	G14_053	'TO->FROM'	'FPL SWITCH - WOODWARD 138KV CKT 1'	133	153	0.03917	123.349	'GRAPEVINE INTERCHANGE - STATELINE INTERCHANGE 230KV CKT 1'
15G	06ALL	G14_054	'TO->FROM'	'FPL SWITCH - WOODWARD 138KV CKT 1'	133	153	0.03917	123.349	'GRAPEVINE INTERCHANGE - STATELINE INTERCHANGE 230KV CKT 1'
15G	06ALL	G14_033	'TO->FROM'	'FPL SWITCH - WOODWARD 138KV CKT 1'	133	153	0.04195	117.9906	'STATELINE INTERCHANGE - STLN-DEMARC6 230KV CKT 1'
15G	06ALL	G14_035	'TO->FROM'	'FPL SWITCH - WOODWARD 138KV CKT 1'	133	153	0.04195	117.9906	'STATELINE INTERCHANGE - STLN-DEMARC6 230KV CKT 1'
15G	06ALL	G14_034	'TO->FROM'	'FPL SWITCH - WOODWARD 138KV CKT 1'	133	153	0.04195	117.9906	'STATELINE INTERCHANGE - STLN-DEMARC6 230KV CKT 1'
15G	06ALL	G14_053	'TO->FROM'	'FPL SWITCH - WOODWARD 138KV CKT 1'	133	153	0.03917	117.9906	'STATELINE INTERCHANGE - STLN-DEMARC6 230KV CKT 1'
15G	06ALL	G14_054	'TO->FROM'	'FPL SWITCH - WOODWARD 138KV CKT 1'	133	153	0.03917	117.9906	'STATELINE INTERCHANGE - STLN-DEMARC6 230KV CKT 1'
15G	06ALL	G14_033	'TO->FROM'	'FPL SWITCH - WOODWARD 138KV CKT 1'	133	153	0.03419	109.5901	'FINNEY SWITCHING STATION - HOLCOMB 345KV CKT 1'
15G	06ALL	G14_035	'TO->FROM'	'FPL SWITCH - WOODWARD 138KV CKT 1'	133	153	0.03419	109.5901	'FINNEY SWITCHING STATION - HOLCOMB 345KV CKT 1'
15G	06ALL	G14_034	'TO->FROM'	'FPL SWITCH - WOODWARD 138KV CKT 1'	133	153	0.03419	109.5901	'FINNEY SWITCHING STATION - HOLCOMB 345KV CKT 1'
15G	06ALL	G14_053	'TO->FROM'	'FPL SWITCH - WOODWARD 138KV CKT 1'	133	153	0.03339	109.5901	'FINNEY SWITCHING STATION - HOLCOMB 345KV CKT 1'
15G	06ALL	G14_054	'TO->FROM'	'FPL SWITCH - WOODWARD 138KV CKT 1'	133	153	0.03339	109.5901	'FINNEY SWITCHING STATION - HOLCOMB 345KV CKT 1'
15G	06ALL	G14_033	'FROM->TO'	'CURRY COUNTY INTERCHANGE - DEAF SMITH REC-#20 115KV CKT 1'	96	96	0.08153	98.2	'DEAF SMITH COUNTY INTERCHANGE - PLANT X STATION 230KV CKT 1'
15G	06ALL	G14_035	'FROM->TO'	'CURRY COUNTY INTERCHANGE - DEAF SMITH REC-#20 115KV CKT 1'	96	96	0.08153	98.2	'DEAF SMITH COUNTY INTERCHANGE - PLANT X STATION 230KV CKT 1'
15G	06ALL	G14_034	'FROM->TO'	'CURRY COUNTY INTERCHANGE - DEAF SMITH REC-#20 115KV CKT 1'	96	96	0.08153	98.2	'DEAF SMITH COUNTY INTERCHANGE - PLANT X STATION 230KV CKT 1'
15G	06ALL	G14_053	'TO->FROM'	'PLANT X STATION - TOLK STATION WEST 230KV CKT 1'	478	502	0.07391	103.6897	'PLANT X STATION - TOLK STATION EAST 230KV CKT 2'
15G	06ALL	G14_054	'TO->FROM'	'PLANT X STATION - TOLK STATION WEST 230KV CKT 1'	478	502	0.07391	103.6897	'PLANT X STATION - TOLK STATION EAST 230KV CKT 2'

Power Flow Analysis

Season	Dispatch Group	Source	Flow	Monitored Element	RATEA (MVA)	RATEB (MVA)	TDF	TC% LOADING	Contingency
15G	06ALL	G14_053	'TO->FROM'	'PLANT X STATION - TOLK STATION EAST 230KV CKT 2'	478	502	0.07338	102.897	'PLANT X STATION - TOLK STATION WEST 230KV CKT 1'
15G	06ALL	G14_054	'TO->FROM'	'PLANT X STATION - TOLK STATION EAST 230KV CKT 2'	478	502	0.07338	102.897	'PLANT X STATION - TOLK STATION WEST 230KV CKT 1'
15G	06ALL	G14_033	'FROM->TO'	'POTASH JUNCTION INTERCHANGE (GE M100747) 230/115/13.2KV TRANSFORMER CKT 1'	150	150	0.0447	96	'CARLSBAD INTERCHANGE - PECOS INTERCHANGE 115KV CKT 1'
15G	06ALL	G14_035	'FROM->TO'	'POTASH JUNCTION INTERCHANGE (GE M100747) 230/115/13.2KV TRANSFORMER CKT 1'	150	150	0.0447	96	'CARLSBAD INTERCHANGE - PECOS INTERCHANGE 115KV CKT 1'
15G	06ALL	G14_034	'FROM->TO'	'POTASH JUNCTION INTERCHANGE (GE M100747) 230/115/13.2KV TRANSFORMER CKT 1'	150	150	0.0447	96	'CARLSBAD INTERCHANGE - PECOS INTERCHANGE 115KV CKT 1'
15G	06ALL	G14_033	'FROM->TO'	'POTASH JUNCTION INTERCHANGE (GE M100747) 230/115/13.2KV TRANSFORMER CKT 1'	150	150	0.0447	99.9	'CARLSBAD INTERCHANGE - PECOS INTERCHANGE 115KV CKT 1'
15G	06ALL	G14_035	'FROM->TO'	'POTASH JUNCTION INTERCHANGE (GE M100747) 230/115/13.2KV TRANSFORMER CKT 1'	150	150	0.0447	99.9	'CARLSBAD INTERCHANGE - PECOS INTERCHANGE 115KV CKT 1'
15G	06ALL	G14_034	'FROM->TO'	'POTASH JUNCTION INTERCHANGE (GE M100747) 230/115/13.2KV TRANSFORMER CKT 1'	150	150	0.0447	99.9	'CARLSBAD INTERCHANGE - PECOS INTERCHANGE 115KV CKT 1'
15G	06ALL	G14_033	'TO->FROM'	'FPL SWITCH - WOODWARD 138KV CKT 1'	133	153	0.03459	110.4141	'THISTLE7 345.00 - WOODWARD DISTRICT EHV 345KV CKT 1'
15G	06ALL	G14_035	'TO->FROM'	'FPL SWITCH - WOODWARD 138KV CKT 1'	133	153	0.03459	110.4141	'THISTLE7 345.00 - WOODWARD DISTRICT EHV 345KV CKT 1'
15G	06ALL	G14_034	'TO->FROM'	'FPL SWITCH - WOODWARD 138KV CKT 1'	133	153	0.03459	110.4141	'THISTLE7 345.00 - WOODWARD DISTRICT EHV 345KV CKT 1'
15G	06ALL	G14_053	'TO->FROM'	'FPL SWITCH - WOODWARD 138KV CKT 1'	133	153	0.03447	110.4141	'THISTLE7 345.00 - WOODWARD DISTRICT EHV 345KV CKT 1'
15G	06ALL	G14_054	'TO->FROM'	'FPL SWITCH - WOODWARD 138KV CKT 1'	133	153	0.03447	110.4141	'THISTLE7 345.00 - WOODWARD DISTRICT EHV 345KV CKT 1'
15G	06ALL	G14_033	'TO->FROM'	'FPL SWITCH - WOODWARD 138KV CKT 1'	133	153	0.03459	110.4141	'THISTLE7 345.00 - WOODWARD DISTRICT EHV 345KV CKT 2'
15G	06ALL	G14_035	'TO->FROM'	'FPL SWITCH - WOODWARD 138KV CKT 1'	133	153	0.03459	110.4141	'THISTLE7 345.00 - WOODWARD DISTRICT EHV 345KV CKT 2'
15G	06ALL	G14_034	'TO->FROM'	'FPL SWITCH - WOODWARD 138KV CKT 1'	133	153	0.03459	110.4141	'THISTLE7 345.00 - WOODWARD DISTRICT EHV 345KV CKT 2'
15G	06ALL	G14_053	'TO->FROM'	'FPL SWITCH - WOODWARD 138KV CKT 1'	133	153	0.03447	110.4141	'THISTLE7 345.00 - WOODWARD DISTRICT EHV 345KV CKT 2'
15G	06ALL	G14_054	'TO->FROM'	'FPL SWITCH - WOODWARD 138KV CKT 1'	133	153	0.03447	110.4141	'THISTLE7 345.00 - WOODWARD DISTRICT EHV 345KV CKT 2'
15G	06ALL	G14_033	'TO->FROM'	'FPL SWITCH - WOODWARD 138KV CKT 1'	133	153	0.03451	115.5276	'GRAPEVINE INTERCHANGE - NICHOLS STATION 230KV CKT 1'
15G	06ALL	G14_035	'TO->FROM'	'FPL SWITCH - WOODWARD 138KV CKT 1'	133	153	0.03451	115.5276	'GRAPEVINE INTERCHANGE - NICHOLS STATION 230KV CKT 1'
15G	06ALL	G14_034	'TO->FROM'	'FPL SWITCH - WOODWARD 138KV CKT 1'	133	153	0.03451	115.5276	'GRAPEVINE INTERCHANGE - NICHOLS STATION 230KV CKT 1'
15G	06ALL	G14_053	'TO->FROM'	'FPL SWITCH - WOODWARD 138KV CKT 1'	133	153	0.03316	115.5276	'GRAPEVINE INTERCHANGE - NICHOLS STATION 230KV CKT 1'
15G	06ALL	G14_054	'TO->FROM'	'FPL SWITCH - WOODWARD 138KV CKT 1'	133	153	0.03316	115.5276	'GRAPEVINE INTERCHANGE - NICHOLS STATION 230KV CKT 1'
15G	06ALL	G14_033	'TO->FROM'	'FPL SWITCH - WOODWARD 138KV CKT 1'	133	153	0.03169	107.8808	'THISTLE7 345.00 - WICHITA 345KV CKT 1'
15G	06ALL	G14_035	'TO->FROM'	'FPL SWITCH - WOODWARD 138KV CKT 1'	133	153	0.03169	107.8808	'THISTLE7 345.00 - WICHITA 345KV CKT 1'
15G	06ALL	G14_034	'TO->FROM'	'FPL SWITCH - WOODWARD 138KV CKT 1'	133	153	0.03169	107.8808	'THISTLE7 345.00 - WICHITA 345KV CKT 1'
15G	06ALL	G14_053	'TO->FROM'	'FPL SWITCH - WOODWARD 138KV CKT 1'	133	153	0.03143	107.8808	'THISTLE7 345.00 - WICHITA 345KV CKT 1'
15G	06ALL	G14_054	'TO->FROM'	'FPL SWITCH - WOODWARD 138KV CKT 1'	133	153	0.03143	107.8808	'THISTLE7 345.00 - WICHITA 345KV CKT 1'

Power Flow Analysis

Season	Dispatch Group	Source	Flow	Monitored Element	RATEA (MVA)	RATEB (MVA)	TDF	TC% LOADING	Contingency
15G	06ALL	G14_033	'TO->FROM'	'FPL SWITCH - WOODWARD 138KV CKT 1'	133	153	0.03169	107.8808	'THISTLE7 345.00 - WICHITA 345KV CKT 2'
15G	06ALL	G14_035	'TO->FROM'	'FPL SWITCH - WOODWARD 138KV CKT 1'	133	153	0.03169	107.8808	'THISTLE7 345.00 - WICHITA 345KV CKT 2'
15G	06ALL	G14_034	'TO->FROM'	'FPL SWITCH - WOODWARD 138KV CKT 1'	133	153	0.03169	107.8808	'THISTLE7 345.00 - WICHITA 345KV CKT 2'
15G	06ALL	G14_053	'TO->FROM'	'FPL SWITCH - WOODWARD 138KV CKT 1'	133	153	0.03143	107.8808	'THISTLE7 345.00 - WICHITA 345KV CKT 2'
15G	06ALL	G14_054	'TO->FROM'	'FPL SWITCH - WOODWARD 138KV CKT 1'	133	153	0.03143	107.8808	'THISTLE7 345.00 - WICHITA 345KV CKT 2'
15SP	06ALL	G14_033	'FROM->TO'	'CURRY COUNTY INTERCHANGE - DEAF SMITH REC-#20 115KV CKT 1'	96	96	0.06534	98.5	'OKLAUNION - TUCO INTERCHANGE 345KV CKT 1'
15SP	06ALL	G14_035	'FROM->TO'	'CURRY COUNTY INTERCHANGE - DEAF SMITH REC-#20 115KV CKT 1'	96	96	0.06534	98.5	'OKLAUNION - TUCO INTERCHANGE 345KV CKT 1'
15SP	06ALL	G14_034	'FROM->TO'	'CURRY COUNTY INTERCHANGE - DEAF SMITH REC-#20 115KV CKT 1'	96	96	0.06534	98.5	'OKLAUNION - TUCO INTERCHANGE 345KV CKT 1'
15SP	06ALL	G14_033	'FROM->TO'	'CURRY COUNTY INTERCHANGE - DEAF SMITH REC-#20 115KV CKT 1'	96	96	0.06383	95.6	'BORDER 7345.00 - WOODWARD DISTRICT EHV 345KV CKT 1'
15SP	06ALL	G14_035	'FROM->TO'	'CURRY COUNTY INTERCHANGE - DEAF SMITH REC-#20 115KV CKT 1'	96	96	0.06383	95.6	'BORDER 7345.00 - WOODWARD DISTRICT EHV 345KV CKT 1'
15SP	06ALL	G14_034	'FROM->TO'	'CURRY COUNTY INTERCHANGE - DEAF SMITH REC-#20 115KV CKT 1'	96	96	0.06383	95.6	'BORDER 7345.00 - WOODWARD DISTRICT EHV 345KV CKT 1'
15SP	06ALL	G14_033	'TO->FROM'	'DEAF SMITH REC-#24 - PARMER COUNTY SUB 115KV CKT 1'	96	96	0.08164	104.0819	'DEAF SMITH COUNTY INTERCHANGE - PLANT X STATION 230KV CKT 1'
15SP	06ALL	G14_035	'TO->FROM'	'DEAF SMITH REC-#24 - PARMER COUNTY SUB 115KV CKT 1'	96	96	0.08164	104.0819	'DEAF SMITH COUNTY INTERCHANGE - PLANT X STATION 230KV CKT 1'
15SP	06ALL	G14_034	'TO->FROM'	'DEAF SMITH REC-#24 - PARMER COUNTY SUB 115KV CKT 1'	96	96	0.08164	104.0819	'DEAF SMITH COUNTY INTERCHANGE - PLANT X STATION 230KV CKT 1'
15SP	06ALL	G14_033	'FROM->TO'	'DEAF SMITH REC-#20 - PARMER COUNTY SUB 115KV CKT 1'	96	96	0.08164	112.2686	'DEAF SMITH COUNTY INTERCHANGE - PLANT X STATION 230KV CKT 1'
15SP	06ALL	G14_035	'FROM->TO'	'DEAF SMITH REC-#20 - PARMER COUNTY SUB 115KV CKT 1'	96	96	0.08164	112.2686	'DEAF SMITH COUNTY INTERCHANGE - PLANT X STATION 230KV CKT 1'
15SP	06ALL	G14_034	'FROM->TO'	'DEAF SMITH REC-#20 - PARMER COUNTY SUB 115KV CKT 1'	96	96	0.08164	112.2686	'DEAF SMITH COUNTY INTERCHANGE - PLANT X STATION 230KV CKT 1'
15SP	06ALL	G14_033	'FROM->TO'	'CURRY COUNTY INTERCHANGE - DEAF SMITH REC-#20 115KV CKT 1'	96	96	0.08164	125.5021	'DEAF SMITH COUNTY INTERCHANGE - PLANT X STATION 230KV CKT 1'
15SP	06ALL	G14_035	'FROM->TO'	'CURRY COUNTY INTERCHANGE - DEAF SMITH REC-#20 115KV CKT 1'	96	96	0.08164	125.5021	'DEAF SMITH COUNTY INTERCHANGE - PLANT X STATION 230KV CKT 1'
15SP	06ALL	G14_034	'FROM->TO'	'CURRY COUNTY INTERCHANGE - DEAF SMITH REC-#20 115KV CKT 1'	96	96	0.08164	125.5021	'DEAF SMITH COUNTY INTERCHANGE - PLANT X STATION 230KV CKT 1'
15SP	06ALL	G14_033	'FROM->TO'	'PLANT X STATION (WH ALM20171) 230/115/13.2KV TRANSFORMER CKT 1'	252	252	0.09207	99.7	'DEAF SMITH COUNTY INTERCHANGE - PLANT X STATION 230KV CKT 1'
15SP	06ALL	G14_035	'FROM->TO'	'PLANT X STATION (WH ALM20171) 230/115/13.2KV TRANSFORMER CKT 1'	252	252	0.09207	99.7	'DEAF SMITH COUNTY INTERCHANGE - PLANT X STATION 230KV CKT 1'
15SP	06ALL	G14_034	'FROM->TO'	'PLANT X STATION (WH ALM20171) 230/115/13.2KV TRANSFORMER CKT 1'	252	252	0.09207	99.7	'DEAF SMITH COUNTY INTERCHANGE - PLANT X STATION 230KV CKT 1'
15SP	06ALL	G14_033	'FROM->TO'	'PLANT X STATION (WH ALM20171) 230/115/13.2KV TRANSFORMER CKT 1'	252	252	0.09207	102.4286	'DEAF SMITH COUNTY INTERCHANGE - PLANT X STATION 230KV CKT 1'

Power Flow Analysis

Season	Dispatch Group	Source	Flow	Monitored Element	RATEA (MVA)	RATEB (MVA)	TDF	TC% LOADING	Contingency
15SP	06ALL	G14_035	'FROM->TO'	'PLANT X STATION (WH ALM20171) 230/115/13.2KV TRANSFORMER CKT 1'	252	252	0.09207	102.4286	'DEAF SMITH COUNTY INTERCHANGE - PLANT X STATION 230KV CKT 1'
15SP	06ALL	G14_034	'FROM->TO'	'PLANT X STATION (WH ALM20171) 230/115/13.2KV TRANSFORMER CKT 1'	252	252	0.09207	102.4286	'DEAF SMITH COUNTY INTERCHANGE - PLANT X STATION 230KV CKT 1'
15SP	06ALL	G14_053	'TO->FROM'	'DEAF SMITH COUNTY INTERCHANGE - PLANT X STATION 230KV CKT 1'	319	351	0.10261	97.4	'NEWHART 230 - PLANT X STATION 230KV CKT 1'
15SP	06ALL	G14_054	'TO->FROM'	'DEAF SMITH COUNTY INTERCHANGE - PLANT X STATION 230KV CKT 1'	319	351	0.10261	97.4	'NEWHART 230 - PLANT X STATION 230KV CKT 1'
15SP	06ALL	G14_033	'FROM->TO'	'CURRY COUNTY INTERCHANGE - DEAF SMITH REC-#20 115KV CKT 1'	96	96	0.06718	98.1	'NEWHART 230 - PLANT X STATION 230KV CKT 1'
15SP	06ALL	G14_035	'FROM->TO'	'CURRY COUNTY INTERCHANGE - DEAF SMITH REC-#20 115KV CKT 1'	96	96	0.06718	98.1	'NEWHART 230 - PLANT X STATION 230KV CKT 1'
15SP	06ALL	G14_034	'FROM->TO'	'CURRY COUNTY INTERCHANGE - DEAF SMITH REC-#20 115KV CKT 1'	96	96	0.06718	98.1	'NEWHART 230 - PLANT X STATION 230KV CKT 1'
15SP	06ALL	G14_033	'FROM->TO'	'PLANT X STATION (WH ALM20171) 230/115/13.2KV TRANSFORMER CKT 1'	252	252	0.10841	104.2679	'NEWHART 230 - PLANT X STATION 230KV CKT 1'
15SP	06ALL	G14_035	'FROM->TO'	'PLANT X STATION (WH ALM20171) 230/115/13.2KV TRANSFORMER CKT 1'	252	252	0.10841	104.2679	'NEWHART 230 - PLANT X STATION 230KV CKT 1'
15SP	06ALL	G14_034	'FROM->TO'	'PLANT X STATION (WH ALM20171) 230/115/13.2KV TRANSFORMER CKT 1'	252	252	0.10841	104.2679	'NEWHART 230 - PLANT X STATION 230KV CKT 1'
15SP	06ALL	G14_033	'FROM->TO'	'PLANT X STATION (WH ALM20171) 230/115/13.2KV TRANSFORMER CKT 1'	252	252	0.10841	106.9429	'NEWHART 230 - PLANT X STATION 230KV CKT 1'
15SP	06ALL	G14_035	'FROM->TO'	'PLANT X STATION (WH ALM20171) 230/115/13.2KV TRANSFORMER CKT 1'	252	252	0.10841	106.9429	'NEWHART 230 - PLANT X STATION 230KV CKT 1'
15SP	06ALL	G14_034	'FROM->TO'	'PLANT X STATION (WH ALM20171) 230/115/13.2KV TRANSFORMER CKT 1'	252	252	0.10841	106.9429	'NEWHART 230 - PLANT X STATION 230KV CKT 1'
15SP	06ALL	G14_053	'TO->FROM'	'PLANT X STATION - TOLK STATION WEST 230KV CKT 1'	478	502	0.0749	131.7326	'PLANT X STATION - TOLK STATION EAST 230KV CKT 2'
15SP	06ALL	G14_054	'TO->FROM'	'PLANT X STATION - TOLK STATION WEST 230KV CKT 1'	478	502	0.0749	131.7326	'PLANT X STATION - TOLK STATION EAST 230KV CKT 2'
15SP	06ALL	G14_053	'TO->FROM'	'PLANT X STATION - TOLK STATION EAST 230KV CKT 2'	478	502	0.07439	130.732	'PLANT X STATION - TOLK STATION WEST 230KV CKT 1'
15SP	06ALL	G14_054	'TO->FROM'	'PLANT X STATION - TOLK STATION EAST 230KV CKT 2'	478	502	0.07439	130.732	'PLANT X STATION - TOLK STATION WEST 230KV CKT 1'
15SP	06ALL	G14_033	'FROM->TO'	'PLANT X STATION (WH ALM20171) 230/115/13.2KV TRANSFORMER CKT 1'	252	252	0.0736	102.4714	'LAMB COUNTY INTERCHANGE - TOLK STATION WEST 230KV CKT 1'
15SP	06ALL	G14_035	'FROM->TO'	'PLANT X STATION (WH ALM20171) 230/115/13.2KV TRANSFORMER CKT 1'	252	252	0.0736	102.4714	'LAMB COUNTY INTERCHANGE - TOLK STATION WEST 230KV CKT 1'
15SP	06ALL	G14_034	'FROM->TO'	'PLANT X STATION (WH ALM20171) 230/115/13.2KV TRANSFORMER CKT 1'	252	252	0.0736	102.4714	'LAMB COUNTY INTERCHANGE - TOLK STATION WEST 230KV CKT 1'
15SP	06ALL	G14_033	'FROM->TO'	'PLANT X STATION (WH ALM20171) 230/115/13.2KV TRANSFORMER CKT 1'	252	252	0.0736	104.8983	'LAMB COUNTY INTERCHANGE - TOLK STATION WEST 230KV CKT 1'
15SP	06ALL	G14_035	'FROM->TO'	'PLANT X STATION (WH ALM20171) 230/115/13.2KV TRANSFORMER CKT 1'	252	252	0.0736	104.8983	'LAMB COUNTY INTERCHANGE - TOLK STATION WEST 230KV CKT 1'

Power Flow Analysis

Season	Dispatch Group	Source	Flow	Monitored Element	RATEA (MVA)	RATEB (MVA)	TDF	TC% LOADING	Contingency
15SP	06ALL	G14_034	'FROM->TO'	'PLANT X STATION (WH ALM20171) 230/115/13.2KV TRANSFORMER CKT 1'	252	252	0.0736	104.8983	'LAMB COUNTY INTERCHANGE - TOLK STATION WEST 230KV CKT 1'
15SP	06ALL	G14_033	'FROM->TO'	'CHAVES COUNTY INTERCHANGE - SAMSON SUB 115KV CKT 1'	120	154	0.16504	102.864	'CHAVES COUNTY INTERCHANGE - URTON SUB 115KV CKT 1'
15SP	06ALL	G14_035	'FROM->TO'	'CHAVES COUNTY INTERCHANGE - SAMSON SUB 115KV CKT 1'	120	154	0.16504	102.864	'CHAVES COUNTY INTERCHANGE - URTON SUB 115KV CKT 1'
15SP	06ALL	G14_034	'FROM->TO'	'CHAVES COUNTY INTERCHANGE - SAMSON SUB 115KV CKT 1'	120	154	0.16504	102.864	'CHAVES COUNTY INTERCHANGE - URTON SUB 115KV CKT 1'
15SP	06ALL	G14_033	'FROM->TO'	'CHAVES COUNTY INTERCHANGE - URTON SUB 115KV CKT 1'	159	160	0.16468	100	'CHAVES COUNTY INTERCHANGE - SAMSON SUB 115KV CKT 1'
15SP	06ALL	G14_035	'FROM->TO'	'CHAVES COUNTY INTERCHANGE - URTON SUB 115KV CKT 1'	159	160	0.16468	100	'CHAVES COUNTY INTERCHANGE - SAMSON SUB 115KV CKT 1'
15SP	06ALL	G14_034	'FROM->TO'	'CHAVES COUNTY INTERCHANGE - URTON SUB 115KV CKT 1'	159	160	0.16468	100	'CHAVES COUNTY INTERCHANGE - SAMSON SUB 115KV CKT 1'
15SP	06ALL	G14_033	'FROM->TO'	'PLANT X STATION (WH ALM20171) 230/115/13.2KV TRANSFORMER CKT 1'	252	252	0.0641	95.5	'GEN525493 1-PLANT X GEN #3'
15SP	06ALL	G14_035	'FROM->TO'	'PLANT X STATION (WH ALM20171) 230/115/13.2KV TRANSFORMER CKT 1'	252	252	0.0641	95.5	'GEN525493 1-PLANT X GEN #3'
15SP	06ALL	G14_034	'FROM->TO'	'PLANT X STATION (WH ALM20171) 230/115/13.2KV TRANSFORMER CKT 1'	252	252	0.0641	95.5	'GEN525493 1-PLANT X GEN #3'

---

## **Stability Analysis**

---

Transient stability analysis was not performed for this LOIS study. The results from DISIS 2014-002-1 or most recent iteration remain valid.

---

## Conclusion

---

<OMITTED TEXT> (Interconnection Customer) has requested a Limited Operation System Impact Study under the Southwest Power Pool Open Access Transmission Tariff (OATT) for a total of 170MW of solar generation to be interconnected with Energy Resource Interconnection Service (ERIS) into the Transmission System of Southwest Public Service (SPS) in Chaves County, Texas. The point of interconnection will be the Chaves 115kV substation. GEN-2014-033, GEN-2014-034, GEN-2014-035, under GIA Section 5.9, have requested this Limited Operation Interconnection Study (LOIS) to determine the impacts of interconnecting to the transmission system before all required Network Upgrades identified in the DISIS-2014-002 (or most recent iteration) Impact Study can be placed into service.

Power flow analysis from this LOIS has determined that GEN-2014-033, GEN-2014-034, GEN-2014-035, request can interconnect their generation at a reduced total of 118MW as an Energy Resource prior to the completion of the required Network Upgrades, listed within Table 2 of this report. Should any other projects, other than those listed within Table 1 of this report, come into service an additional study may be required to determine if any limited operation service is available. Refer to Table 4 for the Limited Operation Interconnection Service available due to interconnection constraints.

Transient stability analysis was not performed for this LOIS study. The results from DISIS 2014-002-1 remain valid.

Any changes to these assumptions, for example, one or more of the previously queued requests not included within this study execute an interconnection agreement and commencing commercial operation, may require a re-study of this LOIS at the expense of the Customer.

Nothing in this System Impact Study constitutes a request for transmission service or confers upon the Interconnection Customer any right to receive transmission service.